

# SP-101

## 3-lines Surge Arrester, common mode



### Description

The SP-101 surge arrester is able to protect up to 3 lines against overvoltages caused by 8/20us surges (lightning) or 10/1000us surges (power switching).

Several levels of protection are available from 18V to 75V.

A thermal protection is added to the lines connected to power supplies.

#### General features

Dimensions	90 mm x 70 mm
Thickness	17,5 mm
Weight	80 g
Assembly	DIN rail
Connections	Screw

#### Climatic conditions

Storage temperature	-20°C to +70°C
Operating temperature	-20°C to +50°C

#### Lines protection

Nominal current ( $I_N$ )	20 kA
Maximum current ( $I_{MAX}$ )	25 kA
Protection levels ( $U_C$ )	18 V <sub>DC</sub> ( 12 V <sub>AC</sub> ) 24 V <sub>DC</sub> ( 16,5 V <sub>AC</sub> ) 48 V <sub>DC</sub> ( 33 V <sub>AC</sub> ) 75 V <sub>DC</sub> ( 50 V <sub>AC</sub> )

#### Lines features

DC serial resistance	0,4 Ω (Signal) 0,8 Ω (Supply)
Serial resistance at 1kHz	1,8 Ω (Signal) 2,2 Ω (Supply)
Maximum current per line	500 mA

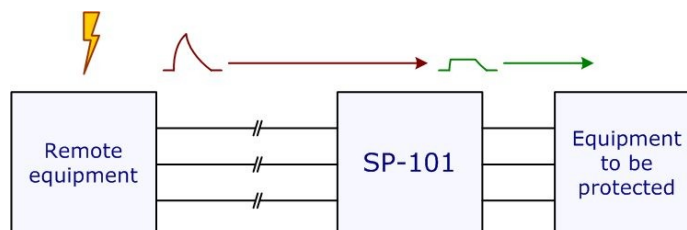

## Available references

The product reference is constructed as follows :

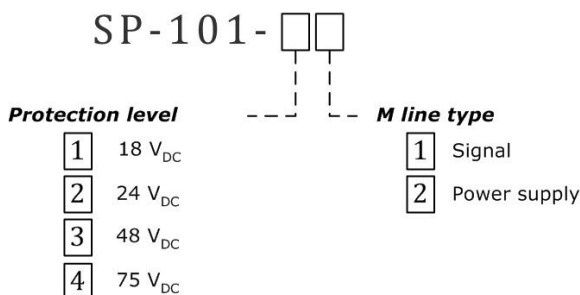

Available references are the following :

SP-101-11	SP-101-21	SP-101-31	SP-101-41
SP-101-12	SP-101-22		

## Overview

The SP-101 module protects up to 3 low-voltage lines against the effects of transients.

All protections are in common mode, the Earth conductor being connected to the DIN rail.

The lines get the following functions :

REF	Voltage reference/ Ground
S	'Signal' line (analog or digital)
M	'Mixed' line

A 'Mixed' line is considered either as a 'Signal' line, either as a 'Supply' line then requiring an additional thermal protection.

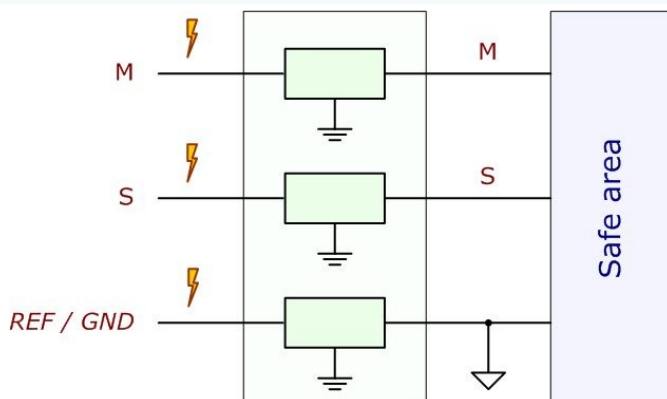

## Lines definitions

### 'Reference' line (REF).

This line acts as a voltage reference. It can be an electronic ground or an other signal.

Protection levels implicitly use this line as a reference. For proper operation of the arrestor, it must be connected.

### 'Signal' line (S or M).

The 'Signal' line is a general purpose line. It can be analog or digital.

### 'Supply' line (M).

This line is connected to a DC power supply.

In some cases, when the arrestor is triggered, the DC supply can maintain it in a state of protection and ultimately damage the arrestor.

An additional protection is added to this line.

## Protection levels

The arrester protection level indicates its maximum operating voltage without tripping.

This voltage, called  $U_c$ , is the maximum steady state voltage.

For proper operation, the M and S lines voltages ( $U_{A2}$  and  $U_{B2}$ ) must remain within the limits of  $\pm U_c$  (REF line used as the reference).

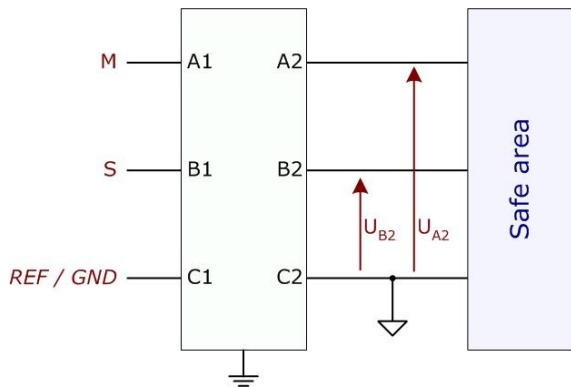

At the triggering of the arrester, the voltage of M and S lines rises above the voltage  $U_c$ . This voltage is called the clamping voltage  $U_R$ .

### Reference SP-101-1x

$U_c$ voltage	18 V <sub>DC</sub> ( 12 V <sub>AC</sub> )
$U_R$ clamping voltage	21,1 V min. 22,0 V typ. 29,2 V max.

### Reference SP-101-2x

$U_c$ voltage	24 V <sub>DC</sub> ( 16,5 V <sub>AC</sub> )
$U_R$ clamping voltage	28,1 V min. 29,4 V typ. 38,9 V max.

### Reference SP-101-31

$U_c$ voltage	48 V <sub>DC</sub> ( 33 V <sub>AC</sub> )
$U_R$ clamping voltage	56,1 V min. 60,1 V typ. 77,4 V max.

### Reference SP-101-41

$U_c$ voltage	75 V <sub>DC</sub> ( 50 V <sub>AC</sub> )
$U_R$ clamping voltage	92,1 V min. 99,0 V typ. 121,0 V max.

## 'Signal' line protection (S)

The S line can be connected to an analog or digital signal, as an input or an output.

Its operating voltage is between  $+U_c$  and  $-U_c$ .

The arrester adds a serial resistance of 0.4  $\Omega$ .

## 'Mixed' line protection (M)

### The M line is a signal.

References SP-101-x1

M and S lines function identically.

They can be connected to an analog or digital signal, as an input or an output.

Their operating voltage is between  $+U_c$  and  $-U_c$ .

The arrester adds a serial resistance of  $0.4\Omega$  to each line.

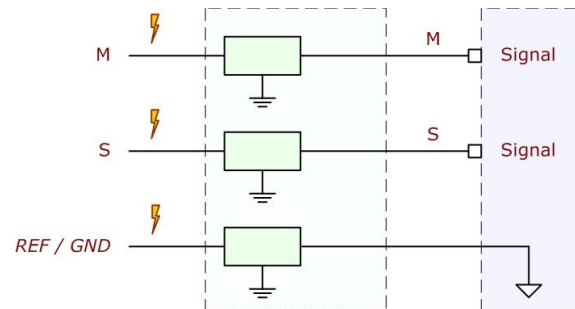

### The M line is a power supply.

References SP-101-x2

The M line has an additional thermal protection.

In some cases, a power supply can prevent the SPD to return to its resting state after tripping due to overvoltage.

The supply voltage is between  $+U_c$  and  $-U_c$ .

The arrester adds a serial resistance of  $0.8\Omega$  on a supply line.

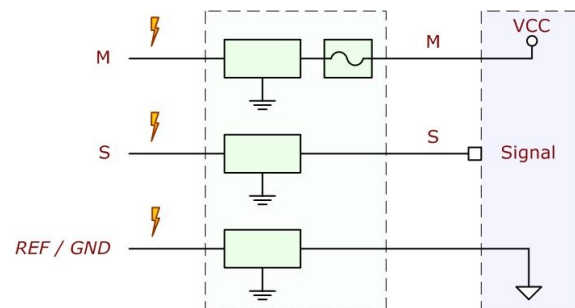

## Earth connection

The SP-101 is connected to the Earth via the DIN rail on which it is mounted.

The user will care to check that:

- DIN rail is in good condition
- The DIN rail is properly connected to the Earth.
- SP-101 module is well fixed on the DIN rail



**Without connection to the Earth, the surge protection is ineffective.**

## Inserted impedance

SP-101 arrester is designed for low frequency equipment.

It shall be preferred for use with signals of frequency less than 10kHz.

The user will care to check the impact of the added impedance by the SPD on its application.

	« Reference » line « Signal » line	« Supply » line
DC	0,4 $\Omega$	0,8 $\Omega$
1 kHz	1,8 $\Omega$	2,2 $\Omega$
3 kHz	4,6 $\Omega$	5,0 $\Omega$
10 kHz	14,3 $\Omega$	14,7 $\Omega$

## Connections

The connections A1, B1 and C1 have to be connected to the equipment that may be exposed to electrical disturbances (lightning, power switching ...).

The connections A2, B2 and C2 are connected to the protected equipment. These connections should be as short as possible.

Line	Non-protected pin	Protected pin
M	A1	A2
S	B1	B2
REF	C1	C2

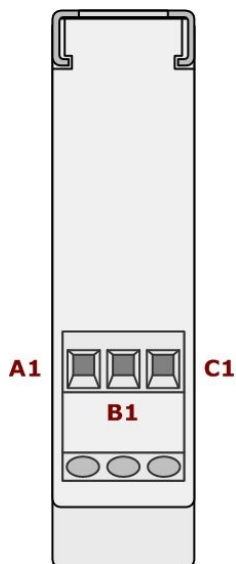

Top view



Front view